

COMBINORM - operating-current operated brakes and clutches use the flux of an electromagnet, concentrated on two pole surfaces, for the connecting, separating or holding of shafts and the connected loads.

COMBINORM covers a complete program with brakes, clutches and combinations as installation and attachment components for the applications in machines, plants and equipment in the application range of 0.5 to 500 Nm.

On request we adapt the **KEB COMBINORM** to your constructional and electrical requirements. Please bear in mind that the rated torques are achieved after a required running-in process.

Program Schedule

COMBINORM Operating-current operated brakes and clutches			
Operating current brake	0.5 ... 500 Nm	page 24	COMBINORM B
Operating current clutch-brake-combination	7 ... 500 Nm	page 26	COMBINORM K
Operating current clutch	0.5 ... 500 Nm	page 26	COMBINORM C
Operating current toothed clutch	21 ... 390 Nm	page 32	COMBINORM T

Technical Data

Switching times	page 34
Moments of inertia, friction, rating	page 35
Dimensioning / Calculations	page 50
Bores table COMBINORM / COMBIPERM	page 51

Ordering example: COMBINORM C



Installation Examples

flange mounted brakes

COMBINORM B .. 02120...

- ① brake magnet
- ② armature
- ⑤ hub
- ⑥ spring

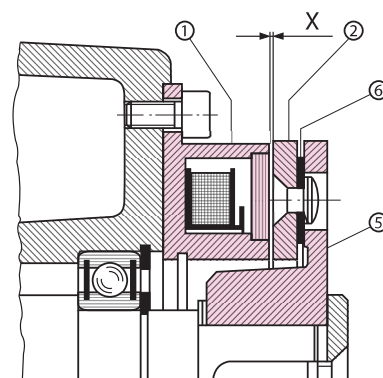

flange mounted clutches

COMBINORM C and T .. 03110...

- ② armature
- ③ clutch magnet
- ④ rotor
- ⑥ spring

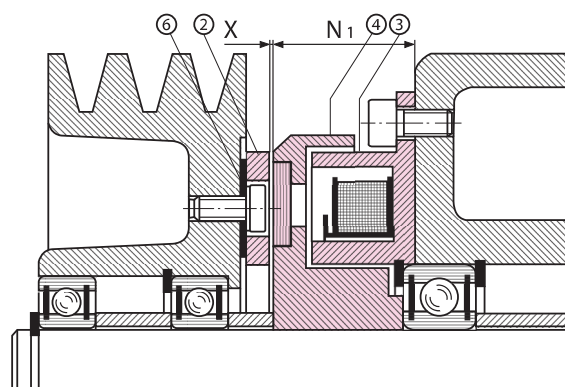

shaft mounted clutches

COMBINORM C and T .. 03810...

- ② armature
- ③ clutch magnet
- ④ rotor
- ⑥ spring

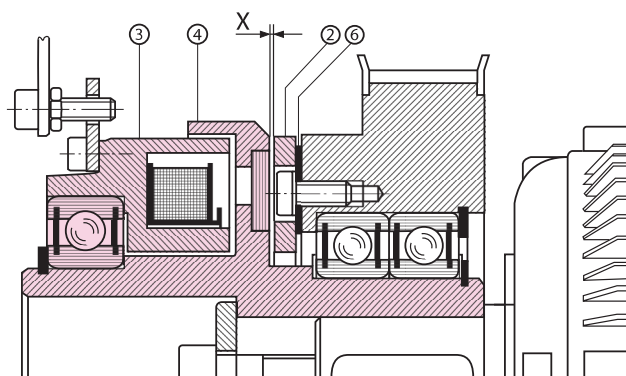

clutch-brake-combination

COMBINORM K .. 04170...

- ① brake magnet
- ② armature
- ③ clutch magnet
- ④ rotor
- ⑤ hub
- ⑥ spring

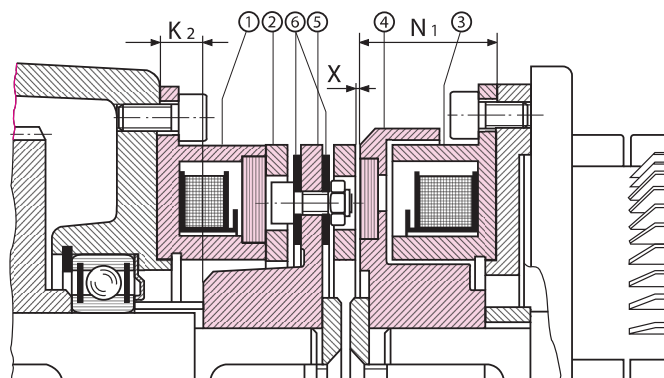

COMBINORM B are the most economical solution for the deceleration and holding of loads for the flange- and shaft-mounted installation in machines and plants. The magnets with a rated voltage of 24 V DC are designed according to ISO class B and are available in various special voltages on request.

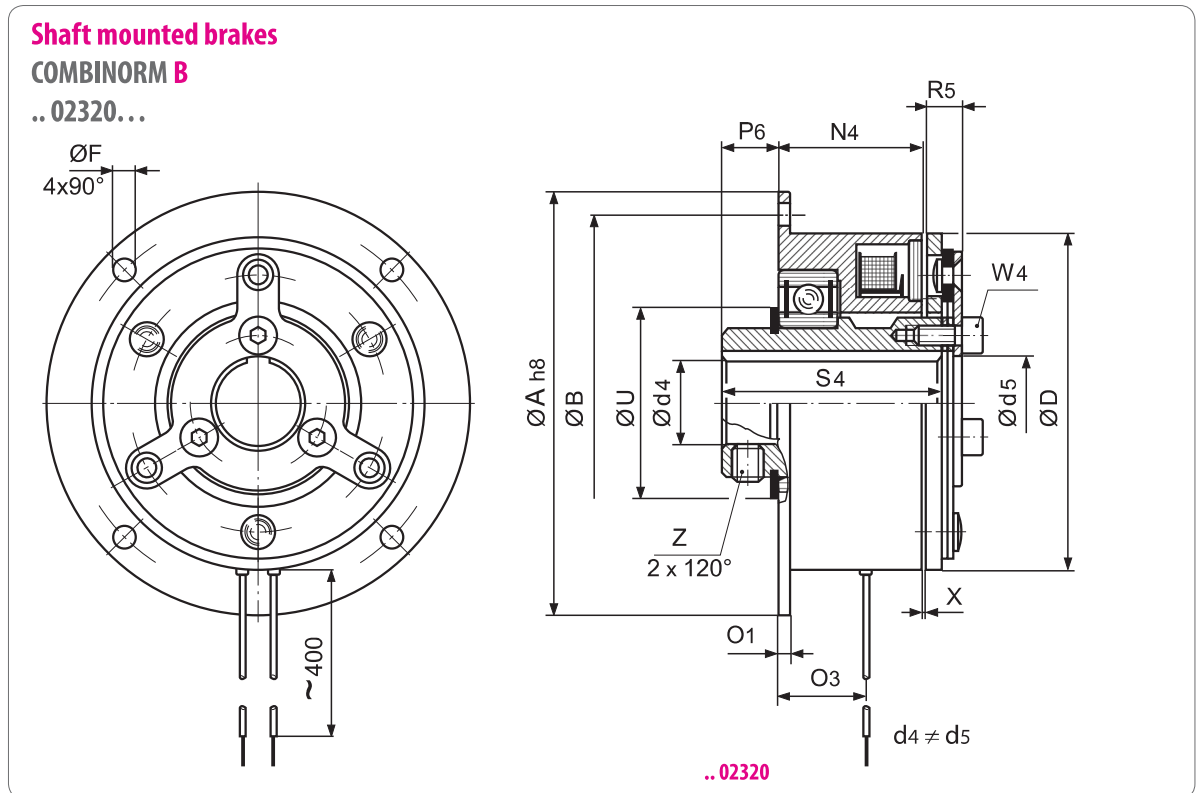

available shaft diameters page 51

Size	$M_{2N}^{(1)}$ [Nm]	P_{20} [W]	A_{h8}	B	C^{H8}	C_1	C_2	d/d ₄ max	d ₅	D	E	F	G	H	J	K	K _f
01	0.5	6	39	33.5	11	13.5	-	6		28	19.5	3.4	2 x 2.1	5.3	4.5	-	-
02	0.75	6	45	38	13	16	13.6	8		32	23	3.4	3 x 2.6	6	5	3	1.1
03	1.5	8	54	47	19	22	20	10		40	30	3.4	3 x 3.1	6	5.5	3	1.1
05	3	10	65	58	26	24	27	15		50	38	3.4	3 x 3.1	6.5	5.5	3.2	1.3
06	7	12	80	72	35	32	36	20	18	63	50	4.5	3 x 4.1	10	8	3.5	1.6
07	15	16	100	90	42	38	43.5	22	21	80	60	5.5	3 x 4.1	11	8	4.25	1.85
08	30	21	125	112	52	48	53.8	30	28	100	76	6.6	3 x 5.1	11.5	10	5	2.15
09	65	28	150	137	62	58	63.8	35	35	125	95	6.6	3 x 6.1	15	11.5	5.5	2.15
10	130	38	190	175	80	73	82.1	45	44	160	120	9	3 x 8.1	21	14.5	6	2.65
11	250	50	230	215	100	92	102.1	60		200	158	9	3 x 10.1	19	17.5	7	3.15
12	500	65	290	270	125	112	127.4	70		250	210	11	4 x 12.1	28	20.5	8	4.15
13	Dimensions and technical data see drawing 02.004-4-01001																

All dimensions in mm Ø „d“ keyway according to DIN 6885/1-P9 (design ..02110/120/130) Ø „d4“ keyway according to DIN 6885/1-H8 (design ..02230)

Range of application: e.g. mail processing, winding equipment, door and gate systems, roller conveyor, strapping machines, balancing machines, sorting machines.

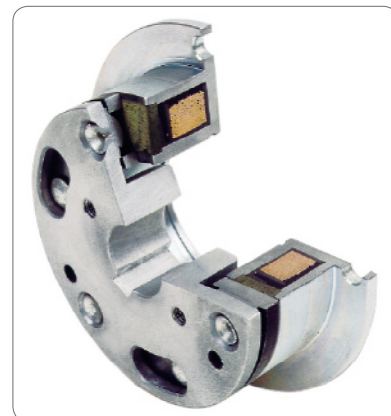

Flange mounted brake
COMBINORM B

.. 021X0...

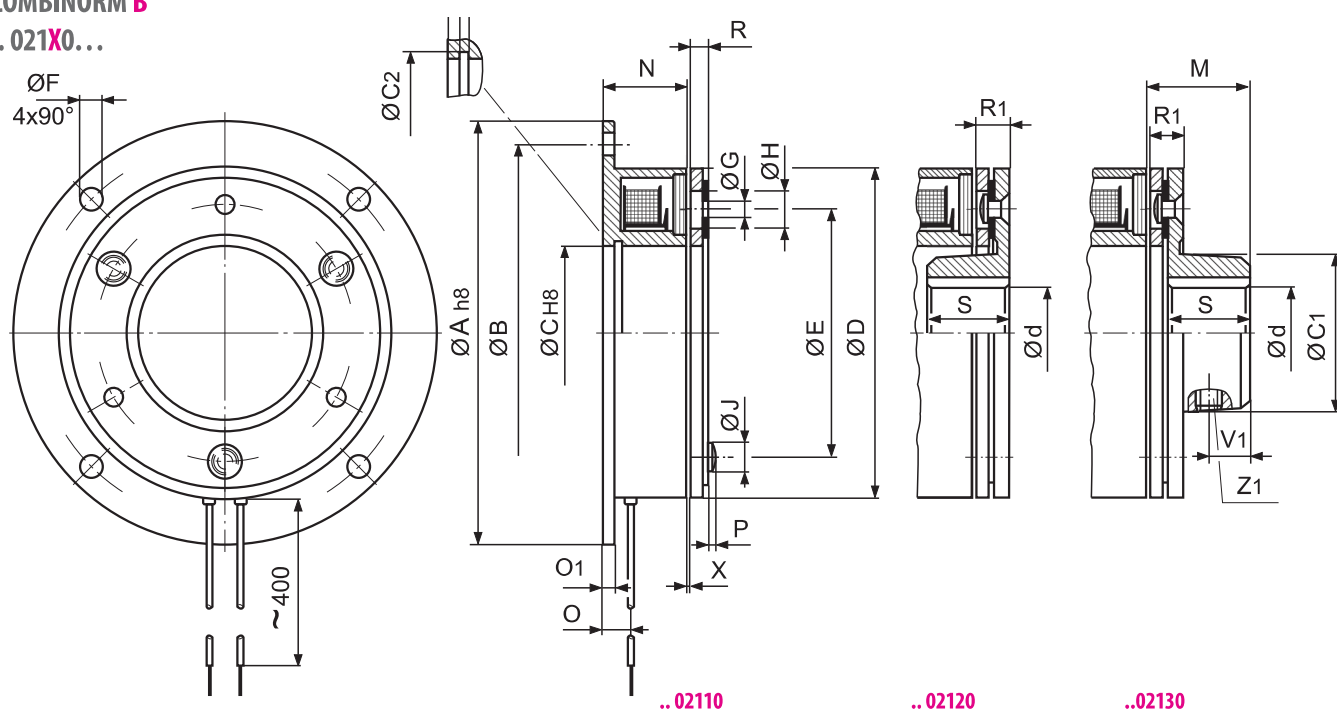

M	N	N ₄	O	O ₁	O ₃	P	P ₆	R	R ₁	R ₅	S	S ₄	U	V ₁	W ₄	X	Z	Z ₁	Weight [kg]		
																			110	120/130	320
9.3	13.7		5	1.5		1		2.3	4.3		7			2.5		0.1		1 x M3	0.05	0.05	
12.1	17		7.5	2		1.3		2.1	4.1		10			4		0.15		1 x M3	0.1	0.1	
14.7	20		7	2		1.5		2.7	5.3		12			5		0.15		1 x M4	0.15	0.15	
15	22		7.5	2		1.5		3	6		12			5		0.2		1 x M5	0.2	0.25	
18.8	18	31.2	6	3	19	2	9.3	3.8	7.3	6.3	15	45	39	6	M4	0.2	M6	1 x M6	0.3	0.3	0.8
24.3	20	34.2	7	3	21.5	2	13.2	4.3	8.3	6.9	20	52.5	45	8	M5	0.2	M8	1 x M6	0.5	0.6	1.5
31	22	38	8	4	24	2.5	13.5	6	11	9.3	25	58.5	56	10	M6	0.2	M8	1 x M8	0.9	1.1	2.7
36.9	24	40	9	4	25	3	13.8	6.9	12.9	10.9	30	62	61	12	M8	0.3	M8	2 x M10	1.7	2	4.2
46.9	26	46.3	11	5	31.5	4	17.3	8.9	15.9	14.1	38	74	84	15	M10	0.3	M10	2 x M10	3.2	4	7.8
59.2	30		12	5		4.5		11.2	20.2		48			19		0.4		2 x M12	5.9	7	
68	35		15	6		5		13	24		55			22		0.4		2 x M12	11.2	13.5	

COMBINORM K covers a series of houseless construction units, designed for the connection and holding of auxiliary drives, allowing a backlash-free transmission with spring-controlled armature systems.

The installation is done directly in the machine construction.

Range of application: e.g. paper processing, laundry folding equipment, feeder

available shaft diameters page 51

Size	M _{2N} ¹⁾ [Nm]	P ₂₀ [W]		A _{h8}	B	C ^{H8}	C ₂ max.	d	d ₁	F	K	K ₁	K ₂	L ₅	N	N ₁	O	O ₁	R ₂	S	S ₆	X	Weight [kg]
		K	B																				
06	7	15	12	80	72	35	36	20	20	4.5	3.5	1.6	11.2	55.1	18	24	6	3	12.9	15	20	0.2	0.85
07	15	20	16	100	90	42	43.5	22	25	5.5	4.25	1.85	9.3	61.3	20	26.5	7	3	14.6	20	22	0.2	1.5
08	30	28	21	125	112	52	53.8	30	30	6.6	5	2.15	8.9	71	22	30	8	4	18.8	25	24.5	0.2	2.7
09	65	35	28	150	137	62	63.8	35	35	6.6	5.5	2.15	7.9	79.6	24	33.5	9	4	21.8	30	27.5	0.3	4.8
10	130	50	38	190	175	80	82.1	45	50	9	6	2.65	5	90.8	26	37.5	11	5	27	38	31	0.3	9.5
11	250	68	50	230	215	100	102.1	60	65	9	7	3.15	3.4	108.2	30	44	12	5	33.8	48	37	0.4	17.9
12	500	85	65	290	270	125	127.4	70	80	11	8	4.15	5.1	125.6	35	51	15	6	39.2	55	43.5	0.4	31.5

All dimensions in mm keyway according to DIN 6885/1-P9 Standard voltage 24 V DC VDE 0580, ISO-class „B“ ¹⁾ rated torque after running in process

COMBINORM C the switchable shaft connections are proven millions of times in the machine building and allow the controlled connection and disconnection of functional parts in an especially easy manner.

Electromagnets according to ISO class B with rated voltage of 24 V DC create a flux, whose effect leads over the pole surfaces of the rotors and armatures.

Available on request in various special voltages.

Range of application: z. B. e.g. paper processing, winding drives, door and gate systems, feed strapping machines, sorting machines

available shaft diameters page 51

Size	M _{2N} ¹⁾ [Nm]	P ₂₀ [W]	A _{h8}	B	C ^{H8}	C ₁	C ₂	d max	d ₁ max	D	E	F	G	H	J	K
01	0.5	6	39	33.5	11	13.5	-	6	6	28	19.5	3.4	2 x 2.1	5.3	4.5	-
02	0.75	6	45	38	13	16	13.6	8	8	32	23	3.4	3 x 2.6	6	5	3
03	1.5	8	54	47	19	22	20	10	10	40	30	3.4	3 x 3.1	6	5.5	3
05	3	10	65	58	26	24	27	15	15	50	38	3.4	3 x 3.1	6.5	5.5	3.2
06	7	15	80	72	35	32	36	18	20	63	50	4.5	3 x 4.1	10	8	3.5
07	15	20	100	90	42	38	43.5	22	25	80	60	5.5	3 x 4.1	11	8	4.25
08	30	28	125	112	52	48	53.8	30	30	100	76	6.6	3 x 5.1	11.5	10	5
09	65	35	150	137	62	58	63.8	35	35	125	95	6.6	3 x 6.1	15	11.5	5.5
10	130	50	190	175	80	73	82.1	45	50	160	120	9	3 x 8.1	21	14.5	6
11	250	68	230	215	100	92	102.1	60	65	200	158	9	3 x 10.1	19	17.5	7
12	500	85	290	270	125	112	127.4	70	80	250	210	11	4 x 12.1	28	20.5	8

All dimensions in mm keyway according to DIN 6885/1-P9 Standard voltage 24 V DC VDE 0580, ISO-class „B“ ¹⁾ rated torque after running in process

Clutch-brake-combination

COMBINORM K

.. 04170...

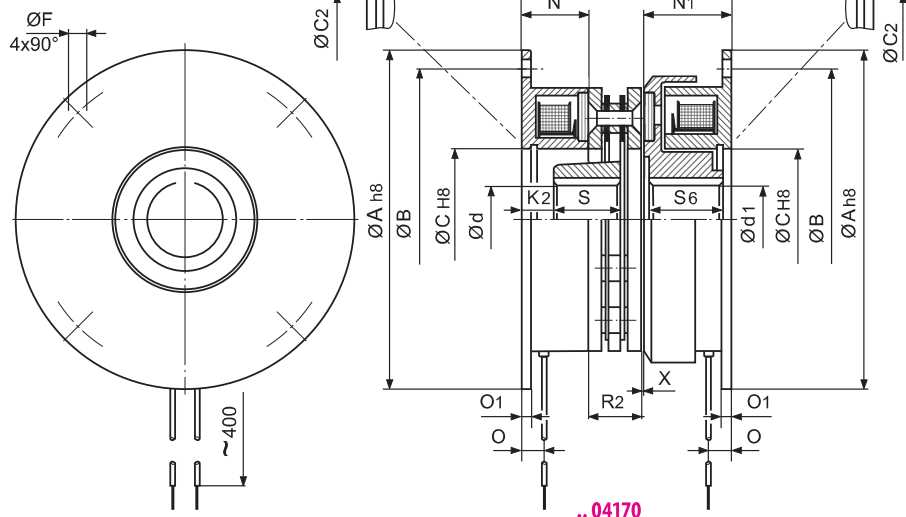

Flange mounted clutches

COMBINORM C

.. 031X0...

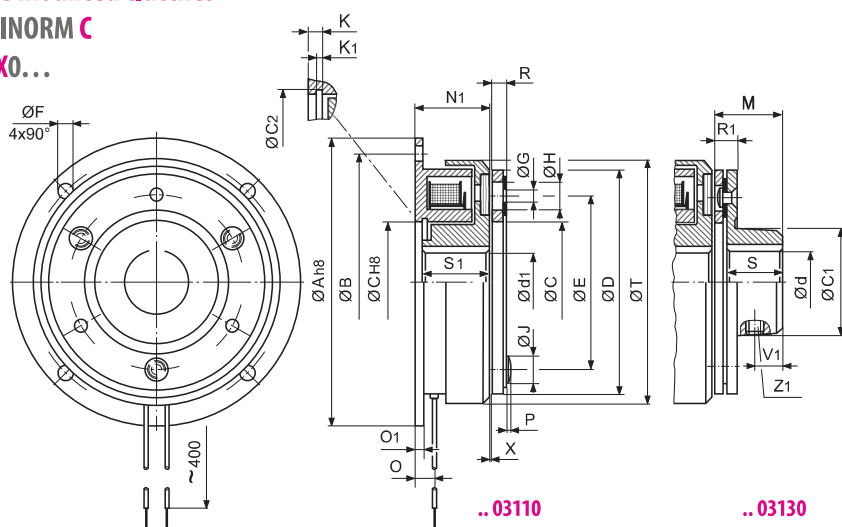

K ₁	M	N ₁	O	O ₁	P	R	R ₁	S	S ₁	T	V ₁	X	Z ₁	Weight [kg]	
														110	130
-	9.3	18	5	1.5	1	2.3	4.3	7	16.5	31	2.5	0.1	1 x M3	0.1	0.1
1.1	12.1	22.2	7.5	2	1.3	2.1	4.1	10	20.2	34	4	0.15	1 x M3	0.1	0.1
1.1	14.7	25.4	7	2	1.5	2.7	5.3	12	23.4	43	5	0.15	1 x M4	0.2	0.2
1.3	15	28.1	7.5	2	1.5	3	6	12	26.1	54	5	0.2	1 x M5	0.35	0.4
1.6	18.8	24	6	3	2	3.8	7.3	15	22	67	6	0.2	1 x M6	0.5	0.5
1.85	24.3	26.5	7	3	2	4.3	8.3	20	24	85	8	0.2	1 x M6	0.9	1
2.15	31	30	8	4	2.5	6	11	25	27	106	10	0.2	1 x M8	1.6	1.8
2.15	36.9	33.5	9	4	3	6.9	12.9	30	30	133	12	0.3	2 x M10	2.8	3.1
2.65	46.9	37.5	11	5	4	8.9	15.9	38	34	169	15	0.3	2 x M10	5.6	6.3
3.15	59.2	44	12	5	4.5	11.2	20.2	48	40	212.5	19	0.4	2 x M12	9.7	11
4.15	68	51	15	6	5	13	24	55	47	266	22	0.4	2 x M12	17.9	20.3

Shaft mounted clutches size 01 ... 07

COMBINORM C

.. 036X0...

table (1)

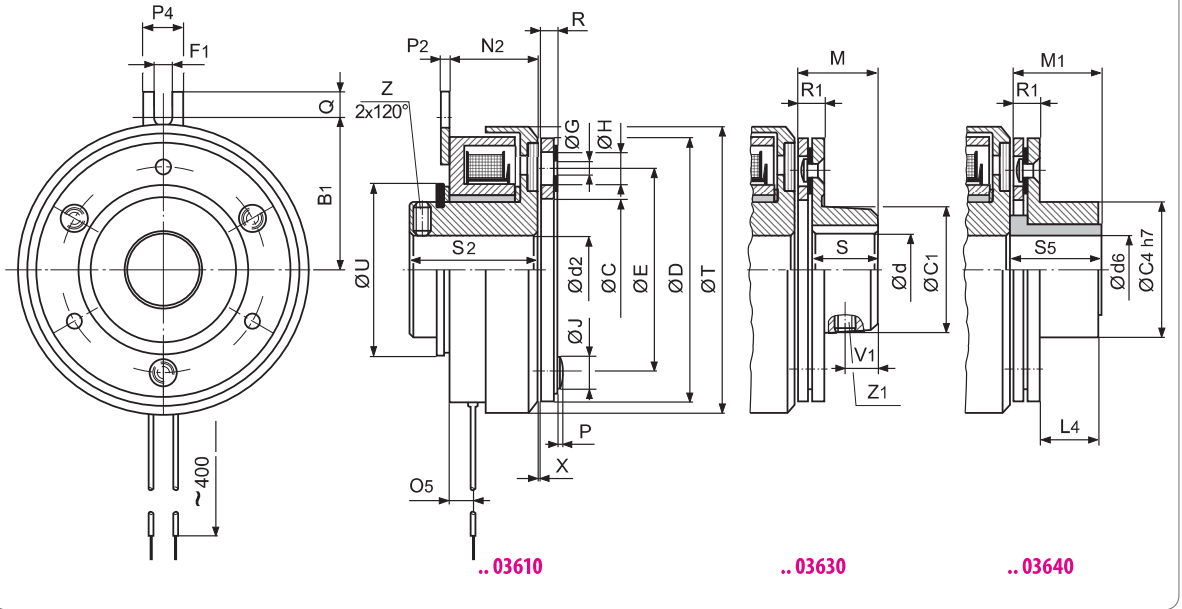

available shaft diameters page 51

table (1)

Size	M _{2N} ¹⁾ [Nm]	P ₂₀ [W]	B ₁	C	C ₁	C ₄	d max	d ₂ max	d ₆ max	D	E	F ₁	G	H	J	L ₄	M	M ₁
01	0.5	6	16.8	11	13.5	13	6	6	6	28	19.5	3.1	2 x 2.1	5.3	4.5	4.8	9.3	9.3
02	0.75	6	20	13	16	14	8	6	6	32	23	3.1	3 x 2.6	6	5	7.8	12.1	12.1
03	1.5	8	23	19	22	18	10	10	10	40	30	3.1	3 x 3.1	6	5.5	9.1	14.7	14.7
05	3	10	28	26	24	28	15	17	15	50	38	3.1	3 x 3.1	6.5	5.5	8.8	15	15
06	7	15	36	35	32	-	18	20	-	63	50	5.2	3 x 4.1	10	8	-	18.8	-
07	15	20	45	42	38	-	22	25	-	80	60	5.2	3 x 4.1	11	8	-	24.3	-

table (2)

Size	M _{2N} ¹⁾ [Nm]	P ₂₀ [W]	A _{h8}	A ₁	B	B ₁	C	C ₁	d max	d ₃ max	D	D ₂	E	E ₁	F	F ₁	G	H	J
06	7	15	80	-	72	-	35	32	18	17	63	-	50	-	4.5	-	3 x 4.1	10	8
07	15	20	100	-	90	-	42	38	22	22	80	-	60	-	5.5	-	3 x 4.1	11	8
08	30	28	-	62.5	-	56	52	48	30	30	100	85	76	45.75	-	6.5	3 x 5.1	11.5	10
09	65	35	-	75	-	68.5	62	58	35	35	125	95	95	55	-	6.5	3 x 6.1	15	11.5
10	130	50	-	95	-	87.5	80	73	45	50	160	126	120	72.5	-	9	3 x 8.1	21	14.5
11	250	68	-	115	-	107.5	100	92	60	50	200	126	158	88	-	9	3 x 10.1	19	17.5
12	500	85	-	145	-	135	125	112	70	60	250	160	210	110	-	11	4 x 12.1	28	20.5

All dimensions in mm keyway according to DIN 6885/1-P9 Standard voltage 24 V DC VDE 0580, ISO-class „B“ ¹⁾ rated torque after running in process

Shaft mounted clutches size 06 ... 12

COMBINORM C

.. 03.XX0...

design torque support

size 08...12

size 06 + 07

design flange

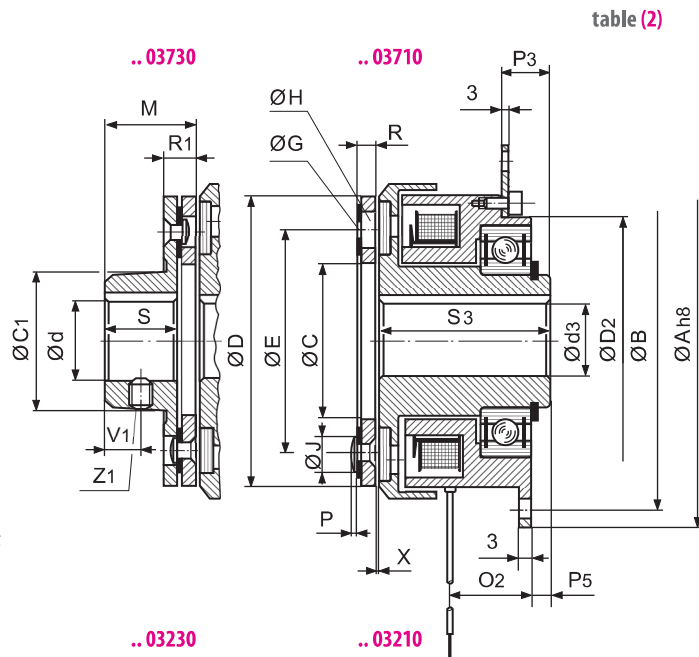
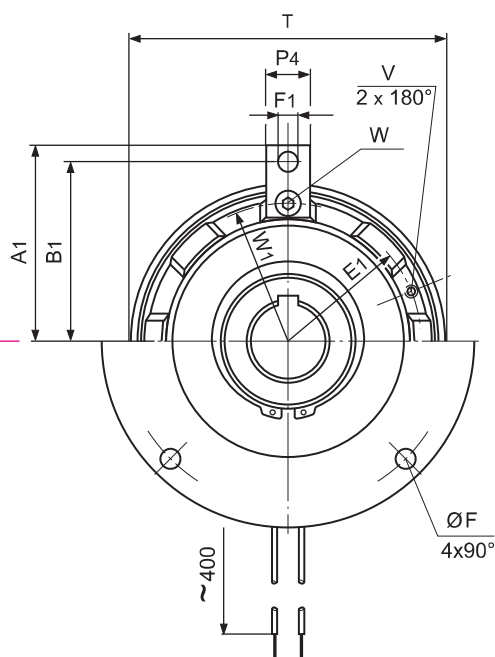
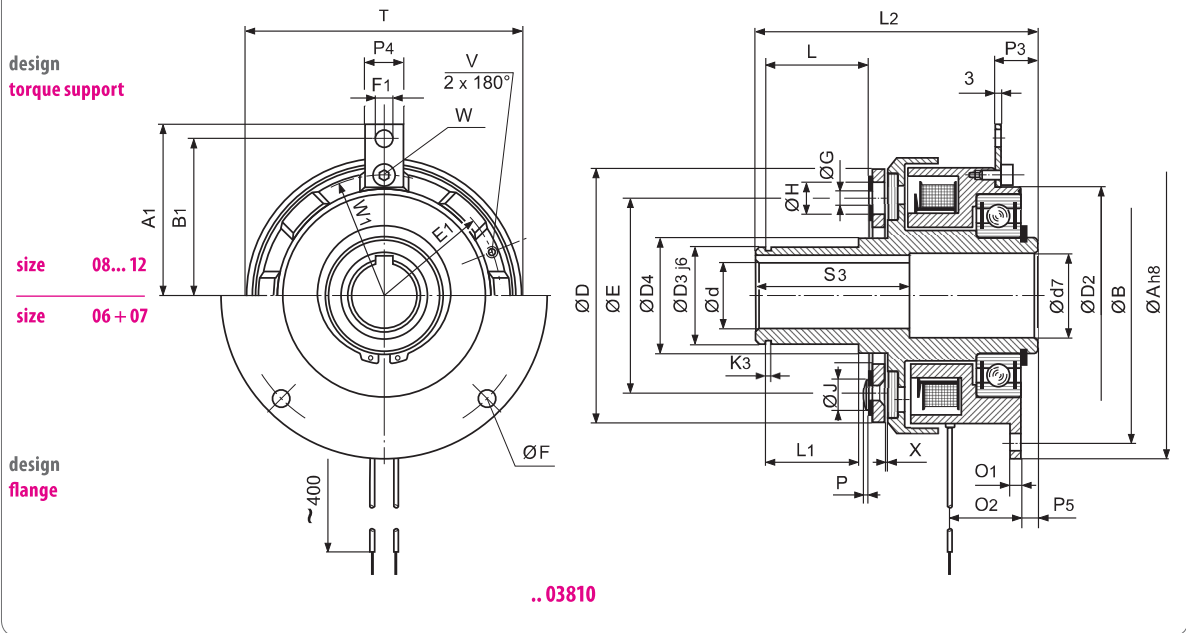

table (2)

N ₂	O ₅	P	P ₂	P ₄	Q	R	R ₁	S	S ₂	S ₅	T	U	V ₁	X	Z	Z ₁	Weight [kg]	
																	110	130
17.3	3.6	1	1.5	8	3	2.3	4.3	7	23.5	9.4	31	17	2.5	0.1	M3	M3	0.1	0.1
19.8	5	1.3	1.5	8	3	2.1	4.1	10	26.2	12.25	34	21	4	0.15	M3	M3	0.1	0.1
23	5.1	1.5	1.5	8	3	2.7	5.3	12	30.4	14.85	43	23	5	0.15	M4	M4	0.2	0.2
26.1	7.8	1.5	1.5	8	3	3	6	12	34.1	15.2	54	32	5	0.2	M4	M5	0.35	0.4
24	6	2	2.5	12	7	3.8	7.3	15	33	-	67	41	6	0.2	M4	M6	0.5	0.5
26.5	7	2	2.5	12	7	4.3	8.3	20	38	-	85	50	8	0.2	M6	M6	0.9	1

M	O ₂	P	P ₃	P ₄	P ₅	R	R ₁	S	S ₃	T	V	V ₁	W	W ₁	X	Z ₁	Weight [kg]	
																	210/710	230/730
18.8	19	2	-	-	4	3.8	7.3	15	41	67	-	6	-	-	0.2	1xM6	0.8	0.9
24.3	21.5	2	-	-	4.5	4.3	8.3	20	45	85	-	8	-	-	0.2	1xM6	1.5	1.6
31	24	2.5	16.2	12	5.5	6	11	25	51.5	106	M5	10	M4	46.5	0.2	1xM8	2.3	2.5
36.9	25	3	18.7	14	5.5	6.9	12.9	30	55	133	M8	12	M5	55	0.3	2xM10	3.7	4.1
46.9	31.5	4	21.5	14	7	8.9	15.9	38	65	169	M8	15	M5	72.5	0.3	2xM10	7	7.7
59.15	32.5	4.5	23	20	7	11.15	20.15	48	71	212.5	M10	19	M6	88	0.4	2xM12	13.1	14.3
68	41	5	41	22	8	13	24	55	85	266	M10	22	M8	110	0.4	2xM12	23	25

Shaft mounted clutches with bearing take-up for the output
COMBINORM C
.. 03810...



available shaft diameters page 51

Size	$M_{2N}^{1)}$ [Nm]	P_{20} [W]	$M_A^{2)}$ [Nm]	A_{h8}	A_1	B	B_1	C_5	D	D_2	D_3	D_4	d_4 max	d_7 max	d	E	E_1	E_2	F	F_1	G
06	7	15	10	80	-	72	-	30	63	-	25	29	19	17	16	50	-	44	4x4.5	-	3x4.1
07	15	20	25	100	-	90	-	40	80	-	35	40	26	25	22	60	-	68	4x5.5	-	3x4.1
08	30	28	25	-	62.5	-	56	45	100	85	40	46	30	28.5	25	76	45.75	80	-	6.5	3x5.1
09	65	35	50	-	75	-	68.5	60	125	95	50	57	38	33	35	95	55	100	-	6.5	3x6.1
10	130	50	140	-	95	-	87.5	85	160	126	70	76	55	41	50	120	72.5	140	-	9	3x8.1
11	250	68	220	-	115	-	107.5	100	200	126	70	76	65	48	50	158	88	165	-	9	3x10.1
12	500	85	500	-	145	-	135	125	250	160	80	89	85	52	60	210	110	215	-	11	4x12.1

All dimensions in mm keyway according to DIN 6885/1-P9 Standard voltage 24 V DC VDE 0580, ISO-class „B“ ¹⁾ rated torque after running in process ²⁾ tightening torque for W_2

For flexible **clutches** (type .. 03840) the following additional instructions are applicable:

The radial and axial screws connecting the rubber element to the hubs must all be tightened to the torque ($M_A^{2)}$) given in the table, using a torque wrench.

Ensure that when tightening the screws the aluminium bushes do not twist in the rubber part and that they sit squarely. In order to reduce friction between the screw head and the aluminium bush smear a small amount of grease under the head of the screw before fitting. If necessary use a suitable tool to apply counter pressure on the element to prevent twisting of the rubber part while tightening the screws. This is particularly important with the radial screws otherwise the curved faces between the aluminium bush and the hub will not engage on the full area but only across the two sides. This will inevitably lead to slackening of the screws and destruction of the clutch. If the clutch is supplied in a pre-assembled state, do not dismantle it, but fit it in this condition.

Shaft mounted clutches with flexible clutch

COMBINORM C

.. 03840...

design
torque support

size 08... 12

size 06 + 07

design
flange

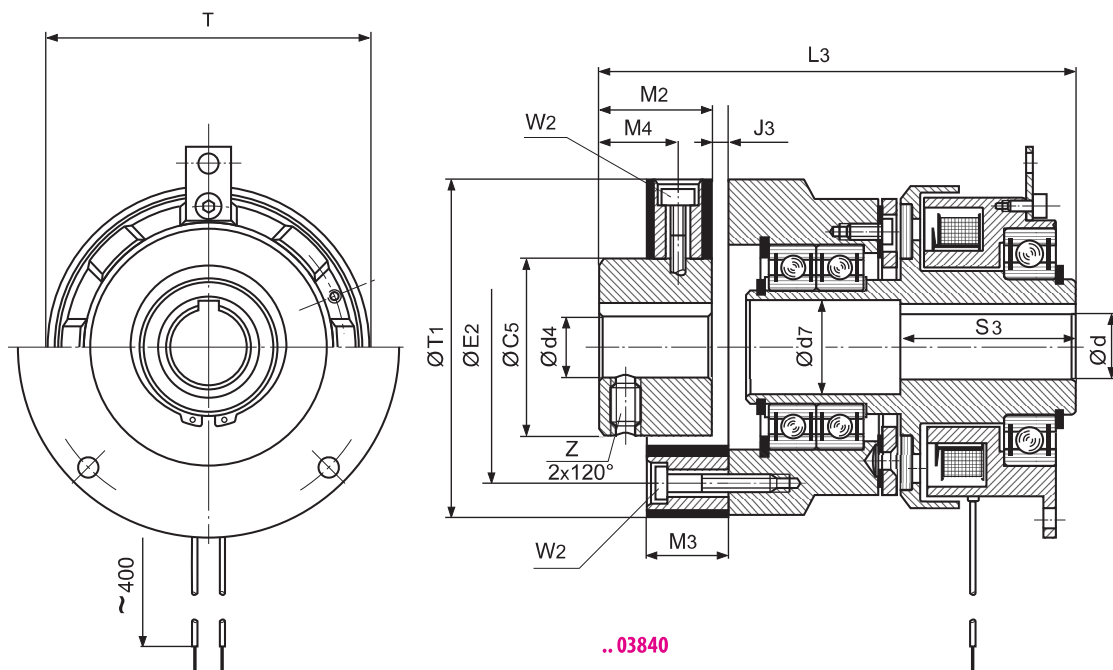

H	J	J ₃	K ₃	L	L ₁	L ₂	L ₃	M ₂	M ₃	M ₄	O ₁	O ₂	P	P ₃	P ₄	P ₅	S ₃	T	T ₁	V	W	W ₁	W ₂	X	Z	Weight [kg]	
																										810	840
10	8	2	1.3	32.9	25.6	80	117	30	24	19	3	19	2	-	-	4	41	67	56	-	-	-	2xM6	0.2	M5	1	1.7
11	8	4	1.6	37.7	29.9	90	129	30	24	20	3	21.5	2	-	-	4.5	45	85	85	-	-	-	2xM8	0.2	M6	1.8	3
11.5	10	4	1.85	35.2	32.15	96	141	35	28	23	-	24	2.5	16.2	12	5.5	51.5	106	100	M5	M4	46.5	3xM8	0.2	M8	2.7	4.1
15	11.5	4	2.15	37.6	34.6	103	160	45	32	31	-	25	3	18.7	14	5.5	55	133	120	M8	M5	55	3xM10	0.3	M10	4.2	7.4
21	14.5	6	2.65	47.8	43.1	126	200	60	46	40	-	31.5	4	21.5	14	7	65	169	170	M8	M5	72.5	3xM14	0.3	M10	8.3	14.6
19	17.5	8	2.65	47.5	43.3	134	217	65	58	40	-	32.5	4.5	23	20	7	82	212.5	200	M10	M6	88	3xM16	0.4	M12	14.5	24.4
28	20.5	8	2.65	59.6	55.3	162	260	80	70	49	-	41	5	27	22	8	85	266	260	M10	M8	110	3xM20	0.4	M12	26	45.2

Size	Compliance [mm] of flexible clutches	
	radial	axial
06	1.5	2
07	1.5	3
08	1.5	3
09	2	4
10	2	5
11	2	5
12	2	5

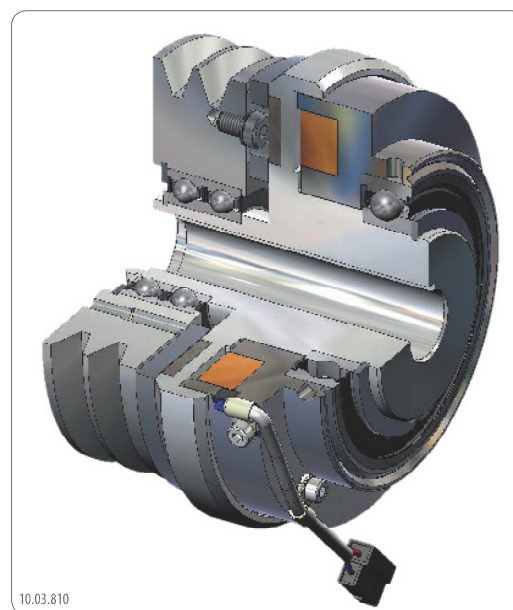

10.03.810

COMBINORM T are electromagnetically operated tooth clutches for wet or dry operation. Torque is transmitted by the leading faces of hardened serrations and is backlash free.

Large torques are transmitted with less space requirements in both directions.

On request available in various special voltages.

Range of application e.g. door drives
printing machines
transport roller
aggregate connection

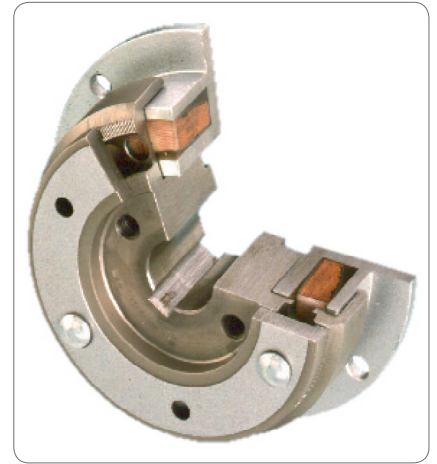

Flange mounted tooth clutches
COMBINORM T
..071X0...

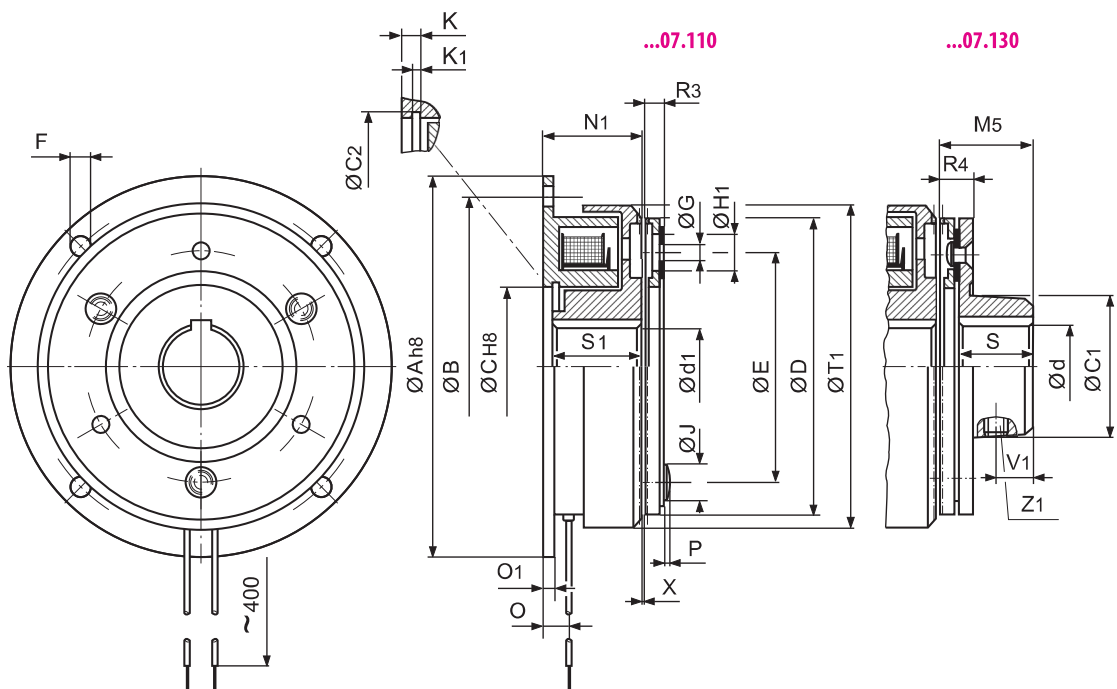

COMBINORM

Shaft mounted tooth clutches

COMBINORM T

.. 07XX0...

design torque support

size 08...10

size 06+07

design flange

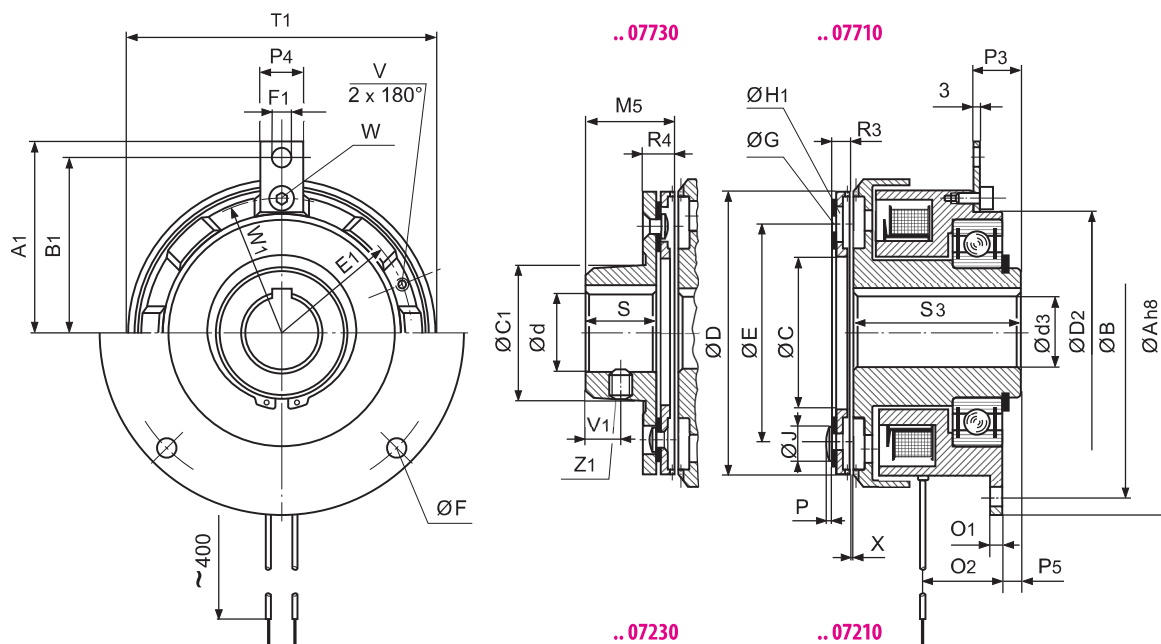

available shaft diameters page 51

Size	M _{2N} [Nm]	P ^{20°C} [W]	A _{h8}	A ₁	B	B ₁	C ^{H8}	C ₁	C ₂	D	d ₁ max	D ₂	d ₃ max	d max	E	E ₁
06	21	15	80	-	72	-	35	32	36	63	20	-	17	18	50	-
07	45	20	100	-	90	-	42	38	43,5	80	25	-	22	22	60	-
08	90	28	125	62,5	112	56	52	48	53,8	100	30	85	30	30	76	45,75
09	195	35	150	75	137	68,5	62	58	63,8	125	35	95	35	35	95	55
10	390	50	190	95	175	87,5	80	73	82,1	160	50	126	50	45	120	72,5

Size	F	F ₁	G	H ₁	J	K	K ₁	M ₅	N ₁	O	O ₁	O ₂	P	P ₃	P ₄	P ₅
06	4x4,5	-	3x4,1	8	8	3,5	1,6	20,3	24	6	3	19	2	-	-	4
07	4x5,5	-	3x4,1	8	8	4,25	1,85	26,4	26,5	7	3	21,5	2	-	-	4,5
08	4x6,6	6,5	3x5,1	11,2	10	5	2,15	33,6	30	8	4	24	2,5	16,2	12	5,5
09	4x6,6	6,5	3x6,1	15	11,5	5,5	2,15	41,2	33,5	9	4	25	3	18,7	14	5,5
10	4x9	9	3x8,1	16	14,5	6	2,65	50,8	37,5	11	5	31,5	4	21,5	14	7

Size	R ₃	R ₄	S	S ₁	S ₃	T ₁	V	V ₁	W	W ₁	X	Z ₁	Weight [kg]			
													210/710	230/730	110	130
06	5,3	8,8	15	22	41	68	-	6	-	-	0,15	1xM6	1	1	0,7	0,7
07	6,4	10,4	20	24	45	86,5	-	8	-	-	0,2	1xM6	1,7	1,8	1,1	1,2
08	8,6	13,6	25	27	51,5	108	M5	10	M4	46,5	0,2	1xM8	2,6	2,8	1,9	2,1
09	11,2	17,2	30	30	55	135	M8	12	M5	55	0,2	2xM10	4,1	4,4	3,2	3,5
10	12,8	19,8	38	34	65	172,2	M8	15	M5	72,5	0,25	2xM10	7,5	8,3	6,1	6,9

All dimensions in mm keyway according to DIN 6885/1-P9 Standard voltage 24V DC VDE 0580, ISO-class „B“

DC-side switching

Current / time and torque / time diagrams

The mentioned designations of switching times are according to DIN VDE 580.

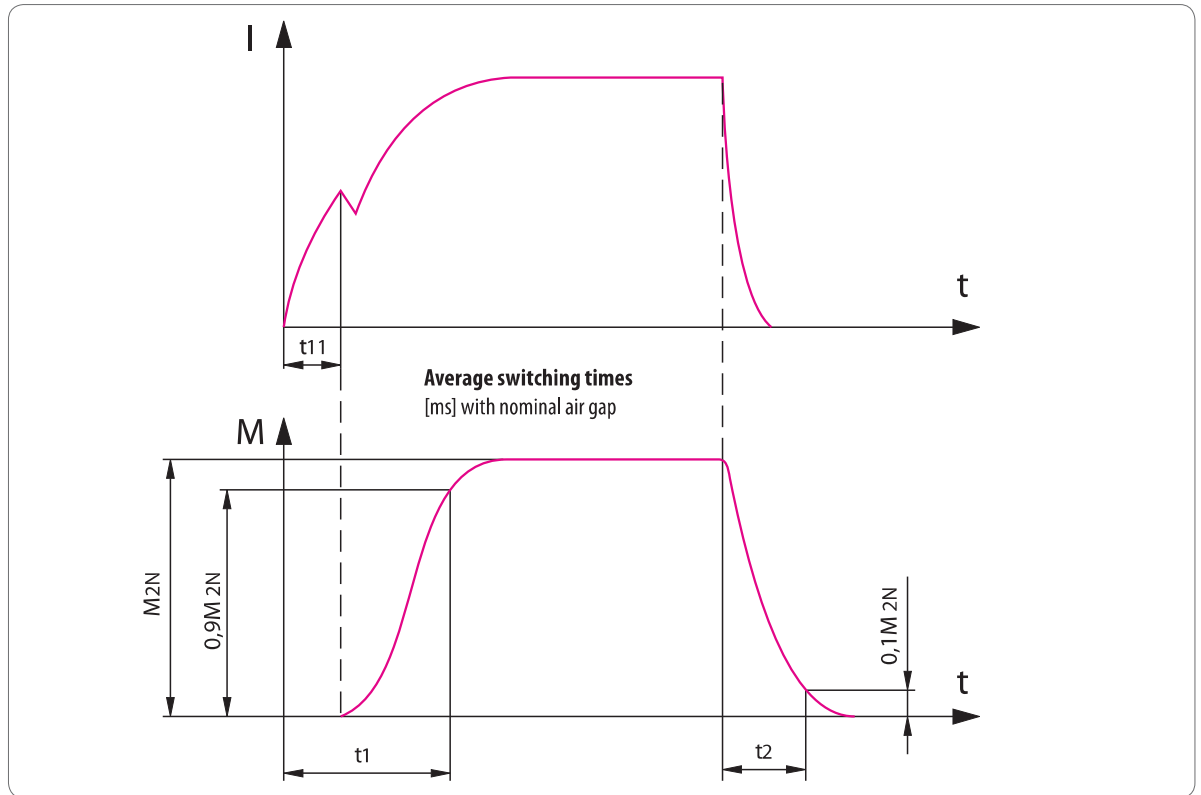

The specified switching times are achieved with adjusted nominal air gap (x_{\min}). It concerns average values whose scattering depends on the current supply and the coil temperature.

The torques specified in the measuring tables are safely achieved with single-side clutches and brakes after a run-in phase at 100 rpm. In new condition and in case of substantially higher speeds the torques are possibly smaller.

Current supply

The **COMBINORM** requires a DC voltage, which can be made available by different rectifiers, transformer rectifiers as well as electronic switches of the series **COMBITRON 91** and **94**.

A short-time overvoltage produces very short switching times and high switching accuracies.

Combinorm 02 / 03 / 04 / 07				01	02	03	05	06	07	08	09	10	11	12
Size														
M_{2N}	02/03/04 07	20 °C	[Nm]	0.5	0.75	1.5	3	7	15	30	65	130	250	500
								21	45	90	195	390		
P₂₀	02/04 brake 03/04/07 clutch	20 °C 20 °C	[W]	6	6	8	10	12	16	21	28	38	50	65
				6	6	8	10	15	20	28	35	50	68	85
J														
Armature	110/210/610/710/810 120/130/230/630/730 320 170		[10 ⁻⁴ kgm ²]	0.010 0.013	0.014 0.021	0.045 0.068	0.122 0.18	0.366 0.53	1.07 1.57	3.72 5.29	10.6 15.1	40 50.1	115 159	311 437
Rotor	110/130/140/170/610 630/640 210/230/240/710/730/740 810			0.025 0.027	0.035 0.038	0.15 0.17	0.375 0.4	0.825 0.9	2.38 2.6	7.25 8	21.9 24	67.4 73	200 220	450 500
W_{Rmax.}	02/03/04		[10 ⁴ J]	0.04	0.05	0.08	0.12	0.19	0.31	0.48	0.75	1.25	2	2.9
W_{RO,1mm}	02/03/04		[10 ⁷ J]	0.23	0.3	0.43	0.63	0.95	1.63	2.53	4.09	6.66	10.4	16.3
P_{Rmax.}	02/04 brake 03/04 clutch		[J/s]	12.8 20.3	18.6 28.6	26.9 40.6	38.9 58.3	58.3 80.6	79.2 114	114 161	164 228	236 322	339 458	489 647
Xn_{max.} 20°	02/03/04 07		[mm]	0.3	0.45	0.45	0.6	0.7 0.15	0.7 0.2	0.7 0.2	0.9 0.2	1.0 0.25	1.2	1.2
X	02/03/04			0.1	0.15	0.15	0.2	0.2	0.2	0.2	0.3	0.3	0.4	0.4
n_{max.}	02/03/04/07 exception clutch! 03.610/630/640		[rpm]	10,000 1,500	10,000 1,500	10,000 1,500	10,000 1,500	8,000 1,500	6,000 1,500	5,000	4,000	3,000	3,000	2,000
Switching times														
Brake 02/04		t ₂ DC	[ms]	3	4	5	8	10	15	50	85	100	140	200
		t ₂ AC		17	20	25	40	70	95	240	300	400	600	800
	nominal voltage	t ₁₁ =		2	3	3	5	6	8	10	13	15	23	35
		t ₁ =		5	8	8	17	24	38	42	48	85	118	155
	3 x nominal voltage	t ₁₁ =		1	2	2	3	3	4	5	6	8	10	16
		t ₁ =		3	4	4	8	11	17	20	22	38	50	76
Clutch 03/04		t ₂ DC	[ms]	5	6	7	10	14	19	40	68	100	130	200
		t ₂ AC		17	19	22	30	39	61	115	220	400	650	900
	nominal voltage	t ₁₁ =		4	5	7	10	14	18	23	25	29	37	55
		t ₁ =		10	14	17	32	48	74	81	90	161	201	295
	3 x nominal voltage	t ₁₁ =		2	2	3	5	6	8	10	12	14	16	25
		t ₁ =		5	6	7	16	22	33	37	42	69	91	125

Legend

M _{2N}	rated torque after running in process	[Nm]	t	time	[ms]
M _{erf}	required torque	[Nm]	t ₁	Engaging time Time from connecting the current the rated torque is attained	[ms]
J	moment of inertia	[10 ⁻⁴ kgm ²]	t ₁₁	Engaging delay time: Time from connecting the current until the torque rises	[ms]
P ₂₀	power at 20 °C	[W]	t ₂	Release time: Time from disconnecting the current until 0.1 M _{2N}	[ms]
n _{max}	maximum speed	[min ⁻¹]			
X	rated air gap	[mm]			
X _n	clearance at which an adjustment is recommended	[mm]			
W _{Rmax}	permissible friction per switching operation	[10 ⁴ J]			
W _{RO,1}	friction work up to 0,1 mm wear	[10 ⁷ J]			
P _{Rmax}	permissible friction work per second	[J/s]			
I	magnet-rated current	[A]			