

KEB COMBISTOP Program Schedule

COMBISTOP are electromagnetically actuated dual surface spring-applied DC brakes for dry application. The braking force is applied by the springs and released through the electromagnetic force. These brakes are successfully working in the most demanding applications and are used wherever rotating masses must be stopped or shafts need to be held in a precise position.

High quality materials together with high precision manufacturing, process inspections and functional testing guarantee reliable, safe operation.

On request we can design the **COMBISTOP** brake to your requirements, for example the brake can be supplied with pre-mounted armature and increased torque.

Please bear in mind that the rated torques are achieved after a required running-in process.

- certified to 

Program Schedule

COMBISTOP	Electromagnetically actuated dual-surface spring applied DC brakes		
Mini brakes	0.3 ... 2 Nm	page 5	COMBISTOP M
Holding brake for dynamic demands	2 ... 1,000 Nm	page 6	COMBISTOP N
Holding brake for static application	5 ... 1,500 Nm	page 6	COMBISTOP H
Holding brake for protection class IP 65	5 ... 250 Nm	page 8	COMBISTOP T
Double-brake for theatre, lift and elevators	2 x 5 ... 2 x 1,000 Nm	page 10	COMBISTOP D
Hoisting brakes, elevator brakes D8	2 x 25 ... 2 x 125 Nm	page 10	COMBISTOP L
Accessories		page 12	

Technical data

Switching times	page 15
Dimensioning / Calculation	page 50
Legend	page 51

Accessories

COMBISTOP	M	N	H	T	D	L
Friction disc		X	X		X	X
Flange	X	X	X	X	X	X
Friction disc with collar		X	X			
Dust protection ring		X	X		X	
Micro switch		X	X		X	X
Hand release	X	X	X	X		X
Terminal box		X	X	X	X	X

COMBISTOP

stands for MINI Brake, the small compact solution with torques up to 2 Nm. The brake is characterized by a particular compact construction, it is designed for small loads and holding functions without torque adjustment and adjustability and available with or without hand release.

Range of application: e.g. general machine building, small-power motors, automation technique, apparatus engineering.

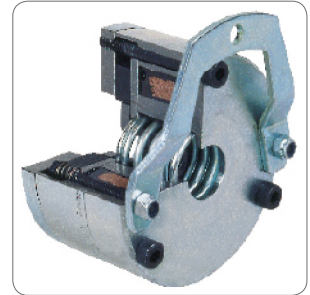

COMBISTOP M
0B08110... without hand release

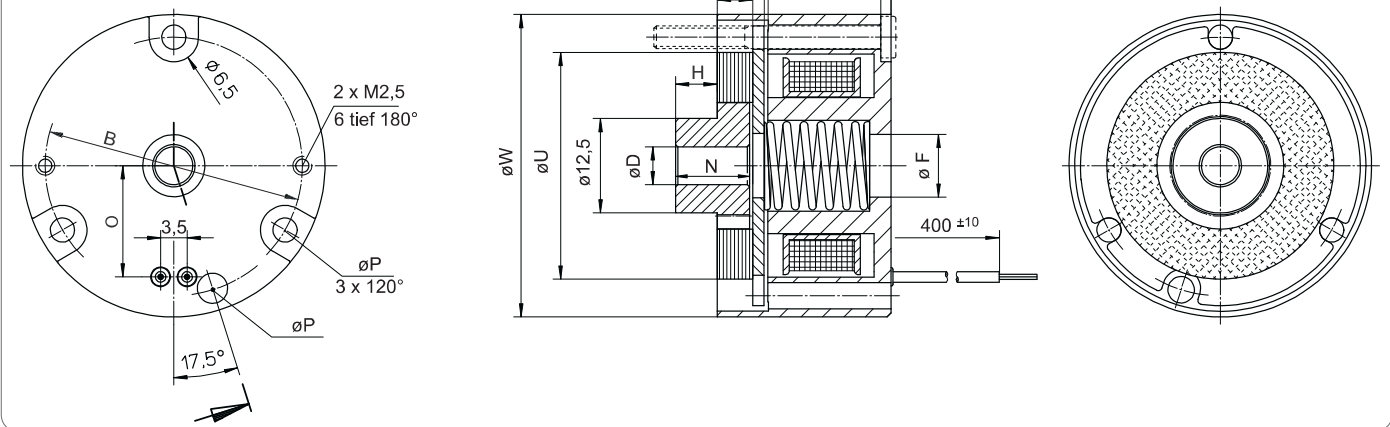

Size	$\frac{M_{2N}^{1)}$ [Nm]	$\frac{P_{20}}{}$ [W]	A	B	D	F	G	H	K	N	O	P	T	U	V	W	X	a_1	b_1	c	e	g	$m^3)$	α°	weight [kg]
0B08	0.3	6		34	5	8.3	23	5.5		9.8	14.7	3.5		30	40	0.1						4.7			0.15
0008	0.5-2	11-15	59.5	52	10 ³⁾	14	29.5	0.5-1	4.5	16	18	4.3	5	43.5	26	59.5	0.15	41	36.5	2	7	5.5	0.8	7	0.4

All dimensions in mm keyway according to DIN 6885/1 according to VDE 0580, isolation class „B“ ¹⁾ rated torque after running in process ²⁾ bore tolerance max Ø 10 mm H7, otherwise H8 ³⁾ Mounting dimension „m“ with attracted armature

COMBISTOP M
0008110... without hand release
0008130... with hand release

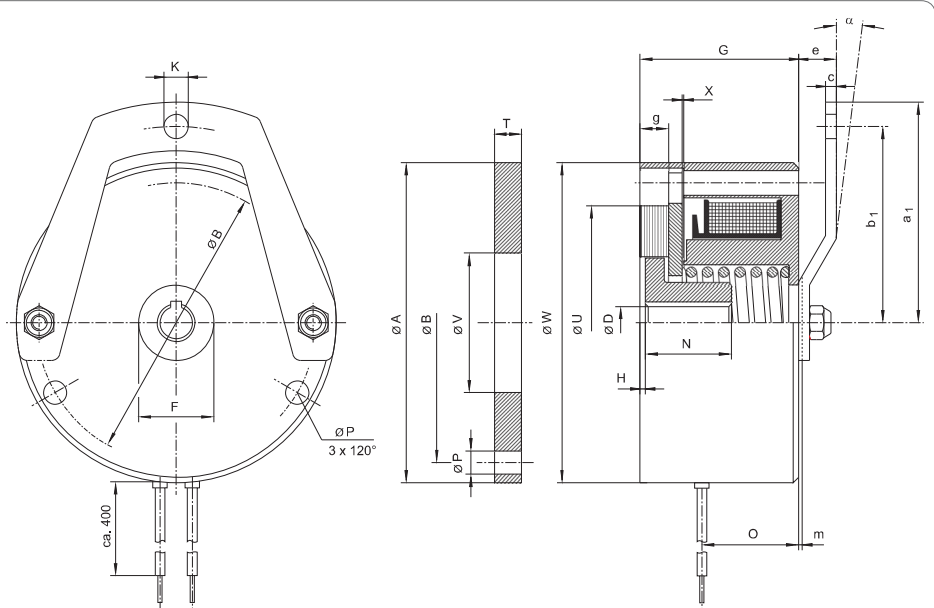

Accessories **COMBISTOP M**
• flange

COMBISTOP N and H are the standard series of dual-surface spring-applied brakes in two designs:

- dynamic applications with continuous stress
- static applications with short-term stress

COMBISTOP N
COMBISTOP H

COMBISTOP N: Rated torque in the range 5 ... 1000 Nm
- designed for dynamic applications with regular brake applications at high speed!

Range of application: e.g. brake motors, geared brake motors, wind energy plants, refrigerated warehouses

Option:

- Cold Climate Version CCV (-40 ... +60 °C)
- ISO-class F + H

Accessories **COMBISTOP N**

- Friction disc
- Flange
- Friction disc with collar (up to size 06)
- Dust protection ring
- Micro switch



COMBISTOP

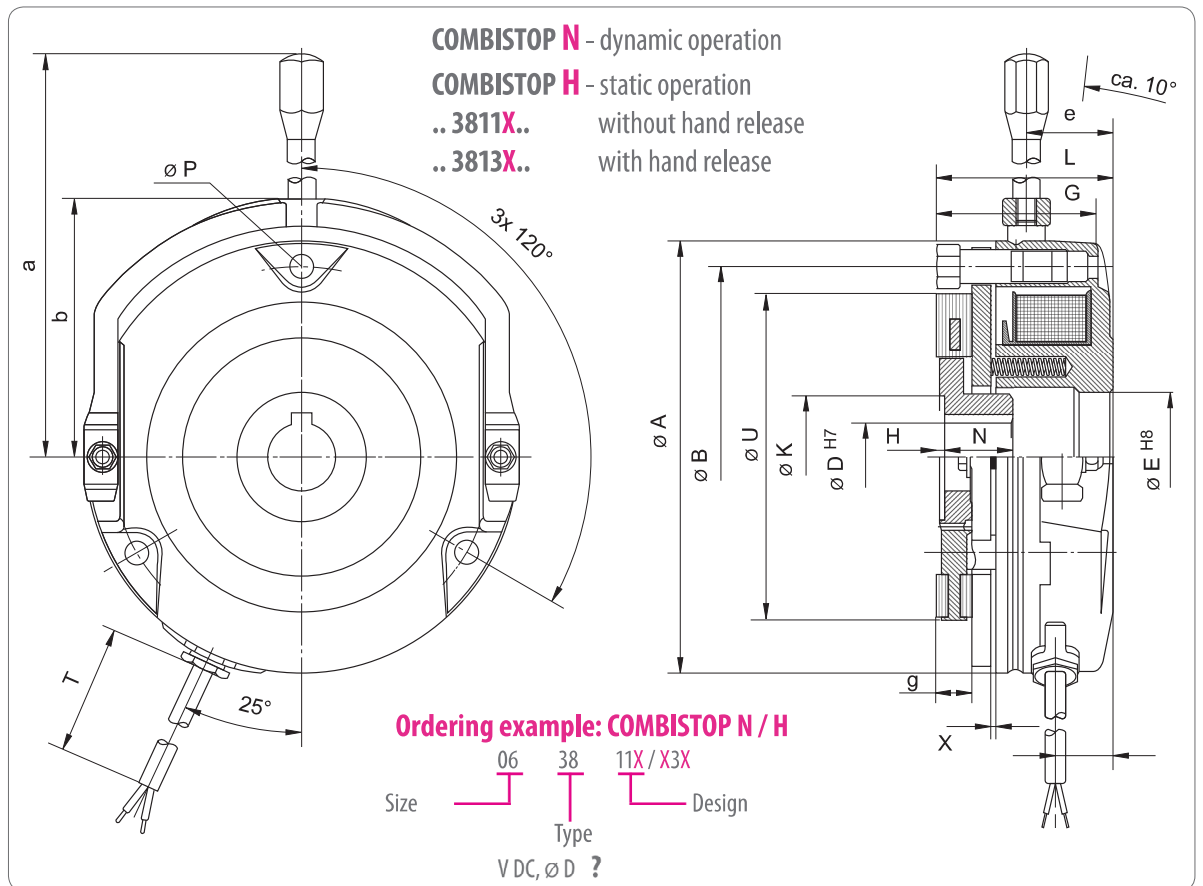

Size	Version „N“		Version „H“		A	B	H7 Ø D max.	E	G	H	K	L	N	O	P	T	U	X	a	b	e	g	weight kg
	M _{2N} ¹⁾	P ₂₀	M _{2N} ¹⁾	P ₂₀																			
	Nm	W	Nm	W																			
02	5	25	7.5	25	85	72	15**	22	34.2	1-1.5	22	37.7	18	11.5	3x4.5	500	60	0.2	105.5	53.5	23	7.5	1
03	10	30	15	30	102	90	20	32	37.2	2-2.5	31	41.7	20	13	3x5.5	500	77	0.2	113	62	25.5	8	1.5
04	20	30	30	30	127	112	25	38	47.2	2-2.5	37	51.7	20	16.5	3x6.5	500	96	0.2	128	76	26.2	10.5	3
05	36	48	50	48	147	132	30	42	52.7	2.5-3	42	57.7	25	18.5	3x6.5	500	115	0.2	168	86	30.5	12	4.5
06	70	62	90	75	164	145	35**	47	59.8	2.5-3	42	68.8	30	20	3x9	500	115	0.3	176	96	39.5	12	7
07	100	65	150	90	190	170	45	62	68	3	57	75.5	30	21.5	3x9	750	149	0.3	225	115	41	14	10
08	150	75	225	90	218	196	60	78	80	4.5	57/76*	*87.4	35	27	3x9	750	175	0.4	235	125	46.5	16	16
09	250	80	375	115	253	230	60	97	88.2	5	76	101.7	40	28	3x11	750	206	0.4	256	146	56	18	26
10	500	130	750	180	307	278	75	120	98.8	9.5	92	110.8	50	25	6x11	750	252	0.5	335	175	59	22	39
11	1,000	180	1,500	280	363	325	90	140	122.1	-	-	134.5	100	30.5	6x13	1,000	300	0.6	***	***	***	30	80

All dimensions in mm keyway according to DIN 6885/1 Standard voltage 24 / 105 / 180 / 205 V DC according to VDE 0580, isolation class „B“, 100% on time, Type of protection IP40, with dust protection ring IP44
¹⁾ rated torque after running in process * hub bore > ø 45 ** keyway according to DIN 6885/3 *** mech. release with hexagon screw

COMBISTOP H: Rated torque in the range 7,5... 1500 Nm - designed for static applications, i.e. braking from low speeds and secure holding of loads!

Range of application: e.g. electronically controlled or regulated drives, wind energy plants, refrigerated warehouses

Accessories COMBISTOP H

- Friction disc
- Flange
- Friction disc with collar (up to size 06)
- Dust protection ring
- Micro switch

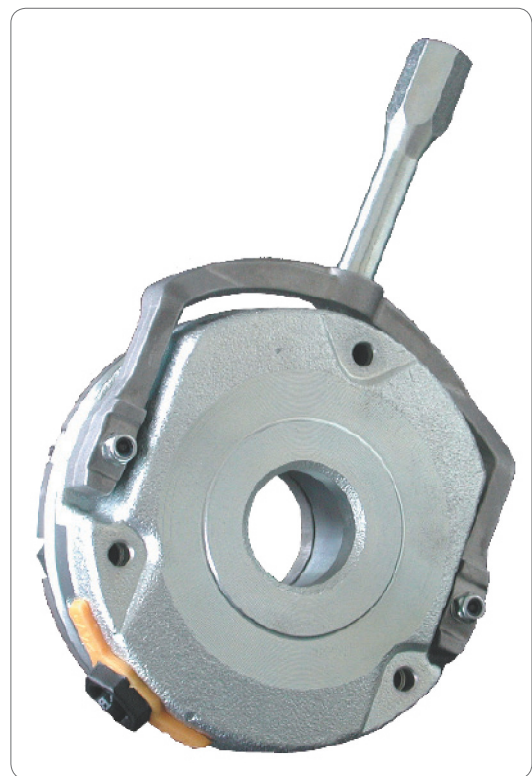

A brake design which are always used whenever the application puts higher demands on the protection class.

COMBISTOP T: the **IP 65**-brake with identical hole circle such as **COMBISTOP N** and **H**, optionally completely closed on the backside or prepared for the attachment of tachogenerators or shaft sealing ring.

Range of application: e.g. general machine building, crane construction, ship gear, wind energy plants, refrigerated warehouses

COMBISTOP T

- ..28G10** standard version without hand release
- ..28G20** standard version with hand release
- ..28G1T** for tachogenerators without hand release
- ..28G2T** for tachogenerators with hand release
- ..28G1W** for shaft sealing ring without hand release
- ..28G2W** for shaft sealing ring with hand release

Size	M _{2N} ¹⁾ [Nm]	P ₂₀ [W]	øA ₁	øA $\frac{h8}{H8}$	øB	C	øD max.	øE	øE ₁	øF	øG	H	øK	L	M	M ₁	N	O
02	5	25	102	98	72	34	15**	50	85	94.5	88	1-1.5	22	39	2.4	88 x 3	18	11
03	10	30	123	118	90	37	20	64	102	116	109.5	2-2.5	31	42.8	2.4	110 x 3	20	12.5
04	20	30	148	143	112	47	25	80	127	138.5	132	2-2.5	37	52.8	2.4	132 x 3	20	16
05	36	48	170	165	132	51.5	30	102	147	158.5	152	2.5-3	42	58.3	2.4	152 x 3	25	17
06	70	62	186	180	145	60	35**	115	164	176.5	170	2.5-3	42	68.8	2.4	170 x 3	30	20
07	100	65	216	210	170	68	45	144	193	200.5	196	2.0	57	74.2	3.5	196 x 4	30	20
08	150	75	246	240	196	77	60	160	217	235.5	225	4.5	$\frac{57}{76}^*$	88	3.2	225 x 4	35	25
09	250	80	280	276	230	86	60	180	254	272	260	5.0	76	102	3.5	260 x 5	40	33

Size	øP	øP ₁	øP ₂	R	T	øV	X	a ₁	b ₁	ød	e	sw	øf	øg	s	k	L ₁	I
02	4.5	8	M4	0.5	6	37	0.2	105.5	53.5	8	22.5	11	22	34	4 x M4	10	36.5	44
03	5.6	10	M5	1.5	7	48	0.2	114	62	8	24	11	32	40	4 x M5	12	40.1	52
04	6.5	11	M6	1.5	9	60	0.2	128	76	8	25.7	11	38	54	4 x M5	12	50.1	66
05	6.5	11	M6	2	9	70	0.2	166	86	10	28	14	42	64	4 x M5	12	56.1	76
06	9	15	M8	2	11	70	0.3	176	96	10	40	14	47	75	4 x M5	12	65.5	88
07	9	15	M8	3.0	12	75	0.3	225	115	14	40	17	62	85	4 x M6	15	73	100
08	9	15	M8	3.5	14	95	0.4	235	125	14	45	17	78	100	4 x M6	15	86	120
09	11	18	M10	4.0	15	95	0.5	256	145	14	40	17	78	110	4 x M6	15	101	130

see dimensions diagram 28.M01-3-0031

All dimensions in mm keyway according to DIN 6885/1 standard voltage 24/105/180/205 V DC according to VDE 0580, ISO-class „B“, 100% on time,
¹⁾ rated torque after running in process * hub bore > ø 45 ** keyway according to DIN 6885/3, **Attention:** under the fixing screws are sealing washer (DIN7603) have to be used

Option: • Cold Climate Version CCV (-40 ... +60 °C) • ISO-class F + H

Accessories **COMBISTOP T**

- Flange
- Hand release
- Shaft sealing ring

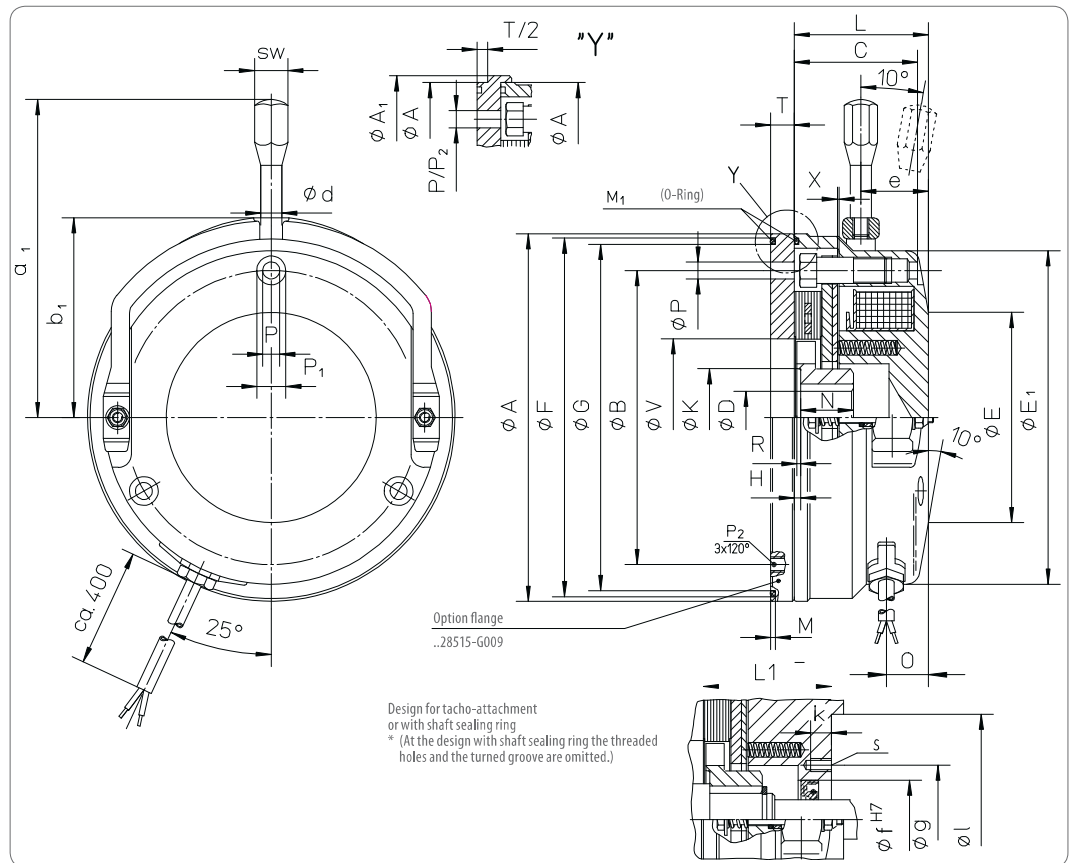

Ordering example: COMBISTOP T

Size	06	28	GXX	Design
	Type			
	VDC, øD ?			

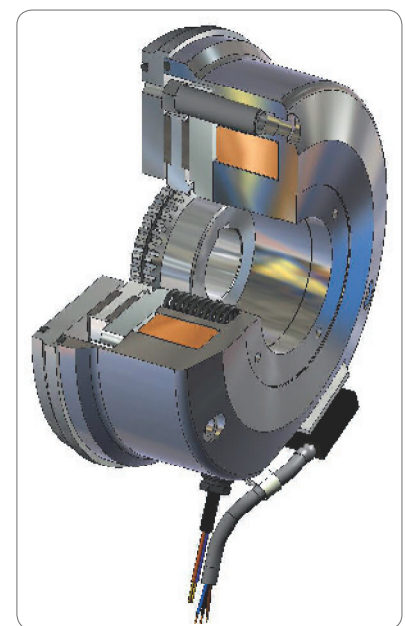

COMBISTOP D stands for **double safety** and covers a series of double brakes, which is prepared for tasks with redundant brake circuits.

The mechanical construction with two completely independent fail-safe spring-applied brakes meets the requirements according to DIN 56950 (BGV C1).

The brakes are supplied ex factory, ready for attachment with preadjusted air gaps.

Extensive constructional measures reduce the switching and running noises to a minimum..

Range of application: e.g. theatre equipment, passenger and freight elevators

Option: ISO class F

Size	$M_{2N}^{(1)}$ (Nm stat)	P_{20} (W)	A	B	C	1 & 2 D (max)	E	F	H	L_1	L_2	M	N_1	N_2	R_1	T	X	a	b	e_1
02	2x5	2x25	85	72	22	15**	22	36	91.2	9.5	1.5	18	27.5	13	8	500	0.2	105.5	53.5	45.5
03	2x10	2x30	102	90	32	20	31	48	106	12.5	2.5	20	34	17	10	500	0.2	114	62	54
04	2x20	2x30	127	112	38	25	37	60	121	12.5	2.5	20	39	23	10	500	0.2	128	76	65
05	2x36	2x48	147	132	42	30	42	70	135	14	3	25	41	21	11	500	0.2	168	86	72
06	2x70	2x62	164	145	47	35**	42	70	157	16	3	30	45	20	13	500	0.3	176	96	81
07	2x100	2x65	190	170	62	45	57	75	180	18.5	3	30	59	37	15	750	0.3	225	115	94
08	2x150	2x75	218	196	78	60	57/76*	100	193	19.5	5	35	55	33	14.5	750	0.3	235	125	97
09	2x250	2x80	254	230	97	60	76	100	224	22	5.5	40	65	45	16.5	750	0.3	256	146	107
10	2x500	2x130	306	278	120	75	92	120	241	27	10	50	63	36	17	750	0.4	335	175	121
11	2x1,000	2x180					upon request													

All dimensions in mm keyway according to DIN 6885/1 standard voltage 24 / 105 / 180 / 205 V DC according to VDE 0580, ISO-class „B“, 100% on time,
¹⁾ rated torque after running in process * hub bore > ø 45 ** keyway according to DIN 6885/3

COMBISTOP L as special development for the elevator industry the dual-circuit spring-applied fail-safe brake fulfills the valid requirements of EN 81 respectively TRA 227.

The brake series, tested by the technical inspection authority, contains two mechanical braking circuits and offers compact dimensions and easy mounting.

Range of application: e.g. passenger and freight elevators, theatre equipment

Option: ISO class F + H

Accessory **COMBISTOP L**

- Friction disc
- Flange
- Micro switch

Size	$2 \times M_{2N}^{(1)}$ (Nm stat.)	P_{20} (W)	A			B			C			D ^{H7}			E			F			G			H		L		N	O	X_n
			A	B	C	D ^{H7}	E	F	G	D8230	D8630	D8230	D8630	N	O	X_n														
05	25	60	154	146	132	30	42	65	147	3	3	53.8	54.3	25	19.5	0.3														
07	50	65	203	188	170	40	57	65	190	3	3	74.3	74.3	30	20	0.4														
09	125	75	268	230	230	60	76	101	254	5	5	98.7	98.7	40	20	0.5														

Size	a	b	d	e		l	m	P_1^* ISO 4762	P_2^* ISO 4762	P_3^* ISO 4762	$2 \times X_v$ D8630	SW	α°	δ°
				D8230	D8630									
05	169	89	10	34.8	35.3	2.5	1.2	M6x65	M6x10	M5x40	0.15	14	10	28
07	225	115	14	33.5	33.5	2.5	1.3	M8x80	M8x12	M6x50	0.20	17	10	25
09	255	145	14	65.7	65.7	3.0	1.4	M10x100	M10x16	M8x75	0.25	17	10	25

All dimensions in mm keyway according to DIN 6885/1 standard voltage 24 / 105 / 180 / 205 V DC according to VDE 0580 ISO-class „B“ 100% on time,
¹⁾ rated torque after running in process * hub bore > ø 45 ** keyway according to DIN 6885/3 see dimension diagram D8.M01-4-0707

Accessories **COMBISTOP D**

- Friction disc
- Micro switch
- Dust protection ring
- Flange
- Friction disc with collar (up to size 06)

Ordering example: **COMBISTOP D**

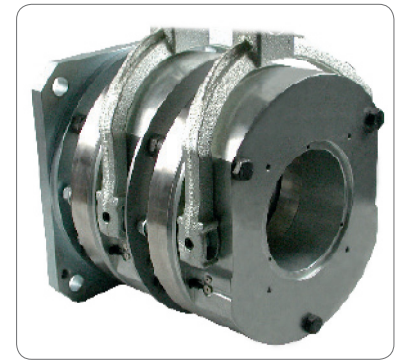
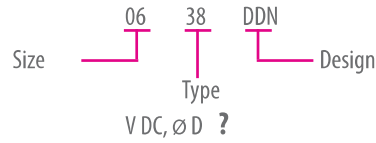

Fastening Screws							
e_2	d_1	d_2	m	Z 1/2/3	Z_1	Z_2	Z_3
22.5	34.6	39	0.8	M4	3x8.8	3x8.8	3x8.8
27	37.7	47.5	1	M5	3x8.8	3x8.8	3x8.8
31	47.8	54.4	1.4	M6	3x8.8	3x8.8	3x8.8
33	53.4	55.9	1.5	M6	3x10.9	3x8.8	3x8.8
36	60.3	64.5	1.8	M8	3x10.9	3x8.8	3x8.8
45	68.8	77.6	2	M8	6x8.8	3x8.8	3x8.8
50	80.8	82.7	2	M8	6x10.9	3x10.9	3x10.9
56	89.4	95.4	2.3	M10	6x8.8	3x10.9	3x10.9
61	99.5	105	2.7	M10	6x10.9	6x8.8	3x8.8

see dimension diagram 38.003-3-0714

COMBISTOP D ..38DDN...

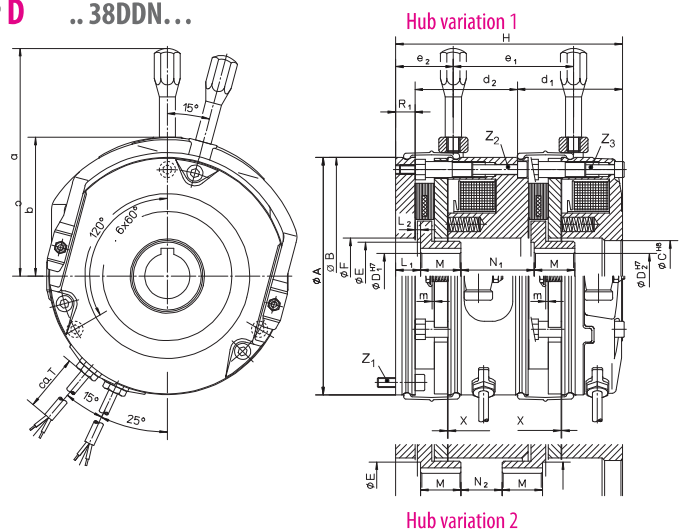

COMBISTOP L .. D8230... with hand release COMBISTOP L .. D8630... with hand release, with backlash-free hub-lining-system

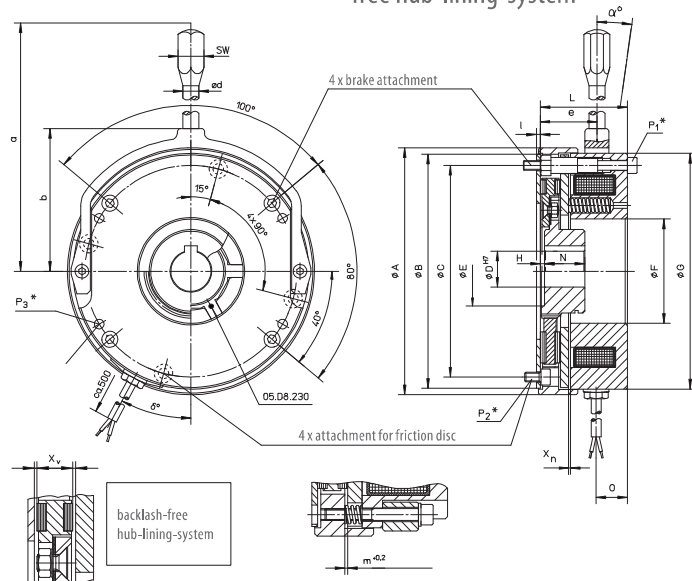

Ordering example: **COMBISTOP L**

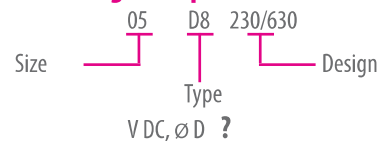

To adapt the spring-applied brakes to the various requirements of different applications an extensive program with a wide range of accessories is available.

Please contact us to discuss your requirements. To ensure correct selection we have on hand an experienced team of application engineers to assist you in all aspects of selection, enabling you to get the optimum solution.

Accessory - dust protection ring (IP44) .. 08550-0009

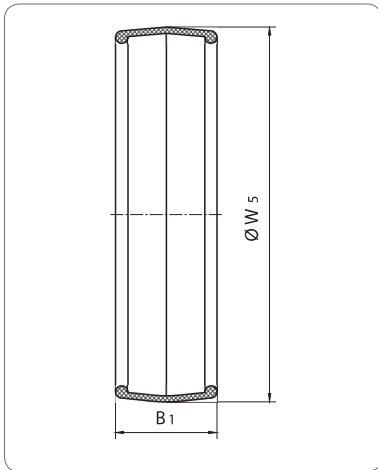

To protect the friction surfaces against dust or dripping water different sizes of dust protection rings are available. When fitting the **COMBISTOP** with a dust protection ring the friction disc **xx08515-xxxx** must be used on the motor side. This friction disc will be supplied nitrated and is especially designed to hold the dust protection ring.

		Article number xx08550-0009									
Size		02	03	04	05	06	07	08	09	10	11
B ₁		22.5	25	33	33.5	38.5	45.5	49	54.5	63	upon request!
W ₅		86	103	129	149	167	195	222	259	310	

all dimensions in mm

Accessory - micro switch

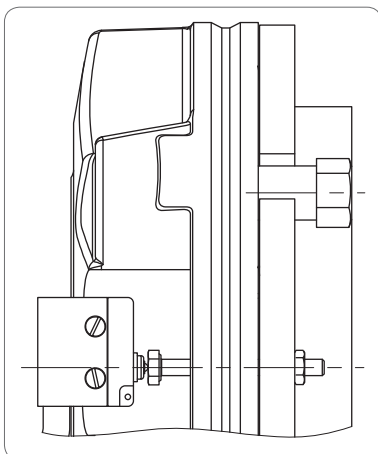

The use of **COMBISTOP** can be fitted with a micro switch for monitoring the functions and the wear. The use of **COMBISTOP** with micro switch is particularly sensible for braking motors on hoisting gears that are operated with frequency inverters.

Friction discs and **flanges** provide suitable counter-rotation surfaces for the spring applied brakes and are available in hardened and rustproof design.

Accessory - friction discs ..08451...

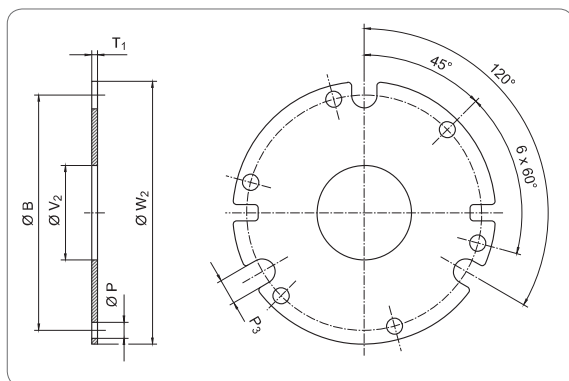

		Article number xx08451-xxxx									
Size		02	03	04	05	06	07	08	09	10	11
B		72	90	112	132	145	170	196	230	278	
P		4.5	5.5	6.5	6.5	9	9	9	11	11	
T ₁		1.5	2	2	2	2.5	2.5	2.5	3	4	
P ₃		7.5	8.5	10.5	10.5	14.5	14.5	14.5	17	17	
V ₂		27	35.5	42.5	47	51	85	100	105	198	
W ₂		82	98	123	146	157	188	214	250	302	
Weight [kg]		0.05	0.10	0.15	0.22	0.30	0.40	0.64	0.93	1.50	

All dimensions in mm

Accessory - friction discs with collar ..08515...

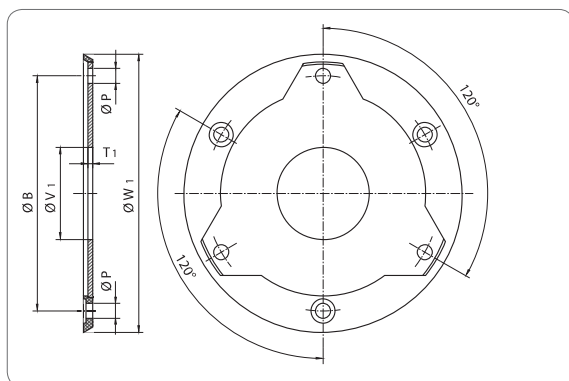

		Article number xx08515-xxxx									
Size		02	03	04	05	06	07	08	09	10	11
B		72	90	112	132	145					
P		4.5	5.5	6.5	6.5	9					
T ₁		1.5	2	2	2	2.5					
V ₁		27	35.5	42.5	47	51					
W ₁		88.5	106	132	153	171					
Weight [kg]		0.05	0.10	0.15	0.25	0.35					

All dimensions in mm

Accessory - flange with collar for dust protection ring ..38510...

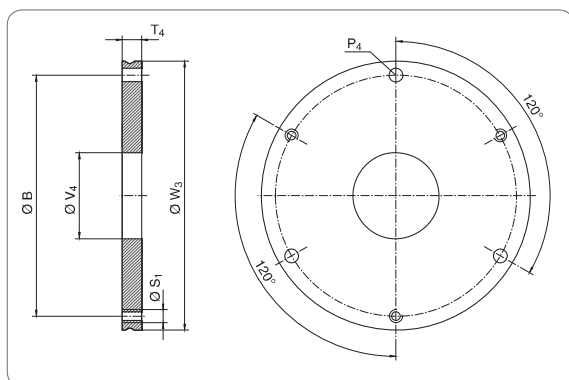

		Article number xx38510-0009										
Size		00	02	03	04	05	06	07	08	09	10	11
B		52	72	90	112	132	145	170	196	230	278	325
P ₄			3x4.3	3x5.3	3x6.4	3x6.4	3x9	3x9	3x9	3x11	6x11	6x13
S ₁			3xM4	3xM5	3xM6	3xM6	3xM8	3xM8	3xM8	3xM10	6xM10	6xM12
T ₄		5	6	7	9	9	11	11	11	11	12.5	20
V ₄		26	20	30	40	45	55	65	75	90	120	160
W ₃		60	83	100	125	145	163	190	217	254	306	363
Weight [kg]		0.08	0.20	0.35	0.75	1	1.50	2.10	2.70	3.70	5.90	12.7

All dimensions in mm

max. speed

Size	Operating-stop [rpm]	max. speed		Type M, T [10 ⁻³ kgm ²]	J Type N, H, D ¹⁾ [10 ⁻³ kgm ²]	g _{min} min. lining thickness [mm]	X _n max. air gap [mm]
		Type M, T emergency stop [rpm]	Typ N, H, D Notbremsung [rpm]				
00	3,000	6,000	-	0.001	-	-	-
02	3,000	6,000	6,000	0.025	0.025	5.5	0.4
03	3,000	6,000	6,000	0.072	0.072	6.5	0.5
04	3,000	6,000	6,000	0.136	0.136	8	0.6
05	3,000	5,000	5,000	0.35	0.35	10	0.6
06	3,000	5,000	5,000	0.56	0.56	10	1
07	3,000	4,500	4,500	1.57	1.57	10	1
08	3,000	3,500	3,500	5.92	5.92	11	1.2
09	1,500	3,000	3,000	7.38	7.38	12	1.2
10	1,500	3,000	3,000	20.54	20.54	14	1.5
11	1,500	3,000	2,000		180.7	28	1.5

g_{min} min. permissible lining thickness [mm]

¹⁾ for brake type D use for calculation 2 x [J]

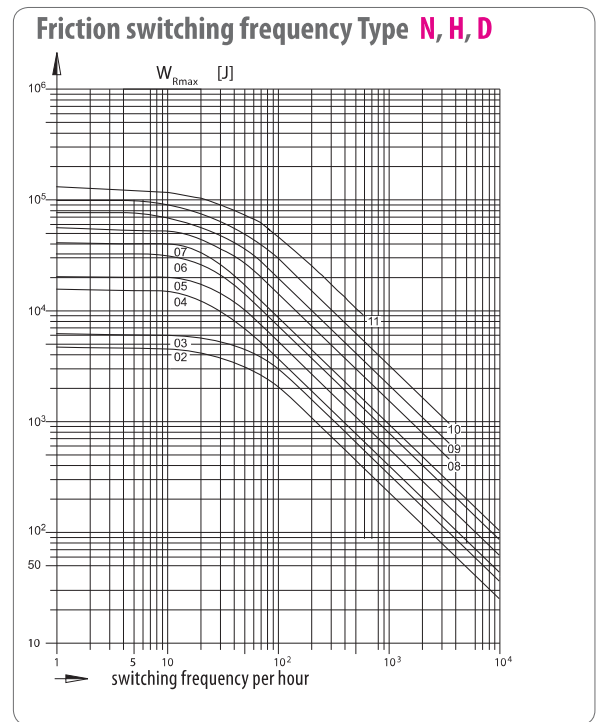
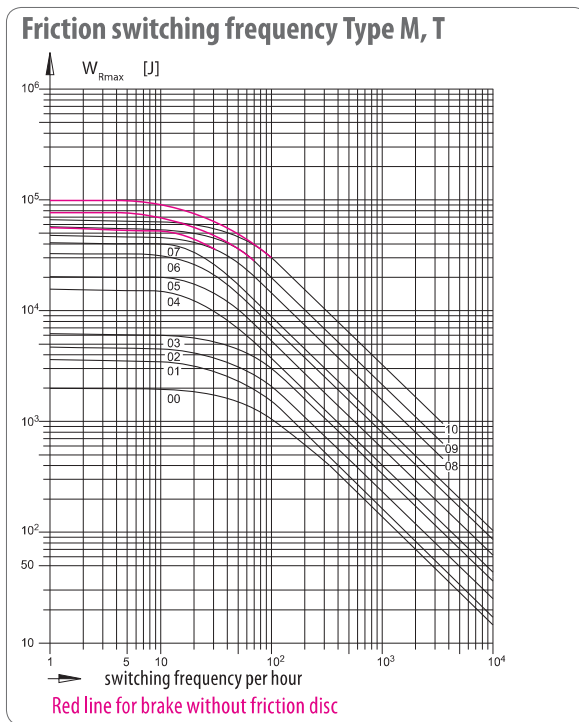

Permissible friction W_{Rmax} [J] dependence on the switching frequency

Valid only for the stated revolutions per minute

type **M, T, N, H, D** size 00 ... 07 - 3000 rpm

type **T, N, H, D** size 08 ... 11 - 1500 rpm

The values for W_{Rmax} are valid for standard brakes and a second friction surface of casting. Depending on application these values may be exceeded or remained under. Rustfree friction discs, or speeds higher than specified in the diagram, reduce the permissible friction work considerably. If the rated torque of the brake is reduced by turning the adjustment ring (optional) the permissible friction work increases.

Switching cycles and switching times

Size	switching cycles						AC-switching				DC-switching			
	SC_1 [rpm]		SC_2 [rpm]		t_2 [ms]		$t_{11\sim}$ [ms]		$t_{1\sim}$ [ms]		$t_{11=}$ [ms]		$t_{1=}$ [ms]	
	M, T	N, H, D	M, T	N, H, D	M, T	N, H, D	M, T	N, H, D	M, T	N, H, D	M, T	N, H, D	M, T	N, H, D
00	70		140		35		60		100		12		25	
02	60	60	120	120	40	40	40	70	90	100	10	10	20	20
03	40	60	75	75	60	55	80	100	140	150	15	15	30	30
04	40	60	75	75	100	90	140	180	200	200	20	25	50	50
05	25	25	50	50	120	110	180	220	240	240	25	25	55	55
06	5	5	10	10	240	240	200	260	330	330	25	25	90	90
07	5	5	10	10	240	220	400	400	650	650	50	40	150	120
08	5	5	10	10	300	320	700	700	900	900	60	50	180	180
09	2	2	5	5	350	350	900	900	1200	1,200	60	60	220	220
10	1	2	3	3	350	400	1,400	1,400	1800	2,000	60	100	250	300
11		1		2		750		3,100		3,500		450		1,000

COMBISTOP Typs: M, T, N, H, D (see page 4)

SC_1 applicable for rectifiers:
0291010-CE07
0291020-CE07
0291010-CEMV

SC_2 applicable for rectifiers:
0491010-CE07
0491020-CE07
0591010-CE09
0691010-CE09

SC maximal permissible switching cycle

at DC-side switching, 100% on time and max. operating temperature of 80 °C. [rpm]

t_1 engaging time

time from disconnecting the current to attaining the rated torque. [ms]

t_{11} engagement delay time

time from disconnecting the current to the rise of the torque. [ms]

t_2 release time

time from connecting the current to the beginning of torque decrease. [ms]

The designation of the switching times corresponds to DIN VDE 580

Switching cycles COMBISTOP with POWERBOX

Size	t_2 [ms]	max. air gap [mm]	switching cycles [rpm]
02	20	1.0	55
03	35	1.8	40
04	50	2.1	40
05	60	3.0	25
06	120	3.0	5
07	120	3.5	5
08	150	3.0	5
09	170	3.5	2
10*	180	4.5	1

* Continuous operation only permissible at 45 °C!

230 V AC input voltage and 105 V DC coil
Switching times apply to rated air gap X
Switching cycles apply to DC-side switching

Power supply

COMBISTOP requires DC voltage for operation. For the power supply different half-wave or full-wave rectifiers of the series **COMBITRON 98** are available for DC or AC-side switching, which, depending on the type, are suitable for connection voltages up to 720 V AC rated voltage.

The switching characteristics and functions of the **COMBISTOP** can be optimized through the rapid switch rectifier **COMBITRON 98..**